

Masoneilan™ 51/52/53 Series

Cylinder Actuator

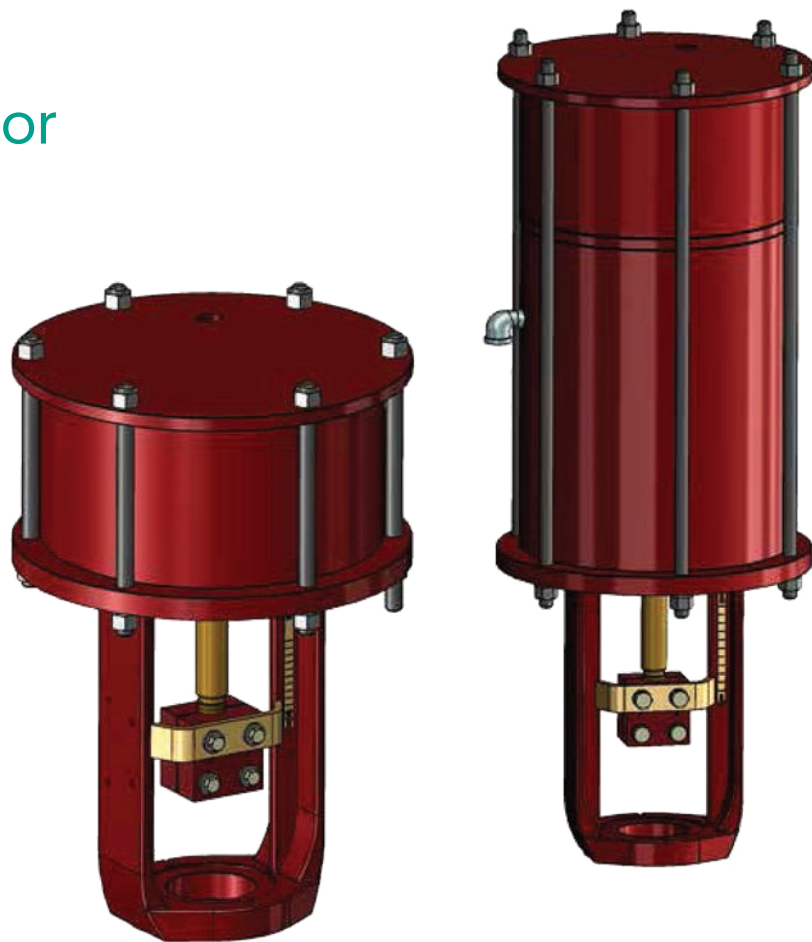

Conversion Table

All the USCS values are converted to metric values using the following conversion factors:

USCS Unit	Conversion Factor	Metric Unit
in.	25.4	mm
lb.	0.4535924	kg
in ²	6.4516	cm ²
ft ³ /min	0.02831685	m ³ /min
gal/min	3.785412	L/min
lb/hr	0.4535924	kg/hr
psig	0.06894757	barg
ft lb	1.3558181	Nm
°F	5/9 (°F-32)	°C

Note: Multiply USCS value with conversion factor to get metric value.

Table of Contents

Features.....	3	Manual Override Options.....	7
Rugged Construction		Valve Mounting Interfaces	8
Application Versatility		Air Connections	9
Safety and Ease of Assembly		Optional Spring Ranges.....	9-10
Long Life Cycle		Materials of Construction.....	11-16
Optional Accessories		Optional Constructions	17
Ease of Maintenance		High Temperature Service.....	17
PED Compliance		Integral Volume Tanks.....	17
Model Numbering System.....	4	Dimensions.....	18-20
Actuator Type		Typical Weights	21-22
Specifications.....	4		
Standard Spring Ranges.....	5		
Stem Travel	6		
Adjustable Travel Stops.....	7		

Features

Masoneilan Model 51/52/53 pneumatic cylinder actuator provides high thrust and dynamic stiffness to meet a variety of throttling control and on/off applications. Some of the key cylinder actuator features include:

Rugged Construction

Heavy internal guiding and support provides proper alignment of the dynamic components, delivering a rugged construction suited for the most demanding valve actuation requirements.

Application Versatility

Standard construction options include double-acting without springs, as well as heavy mechanical spring-return for both air-to-extend and air-to-retract operation. Air volume in the cylinder is reduced in each design, providing high dynamic stiffness and improving speed of response.

Safety and Ease of Assembly

The standard spring-return design includes separate spring cartridge subassemblies, which allow for safe pre-compression of the springs prior to final assembly into the actuator cylinder. The spring cartridge subassembly is also fully field reversible, which helps to reduce plant inventory.

Long Life Cycle

Heavy guiding of the actuator stem results in excellent mechanical alignment of the key components, thus minimizing dynamic seal and sliding surface wear. This also helps to reduce overall operating friction, which enhances throttling control performance.

Optional Accessories

Fail action mode for the double-acting configuration without springs can be provided using an integral volume tank design. There is also an optional manual override available for all actuator sizes. Standard materials are the same for all actuator sizes. Optional handwheel/handjack assemblies provide manual override in case of air failure.

Ease of Maintenance

Modular construction of the cylinder and spring cartridge design provides an assembly that is both easy and safe to maintain. The actuator piston is located in a separate cylinder chamber, which allows for simple dynamic seal replacement.

PED Compliance

The Model 51/52/53 conforms to European Pressure Equipment Directive (PED) requirements.

Please consult your local Baker Hughes sales representative for any additional product information.

Numbering System

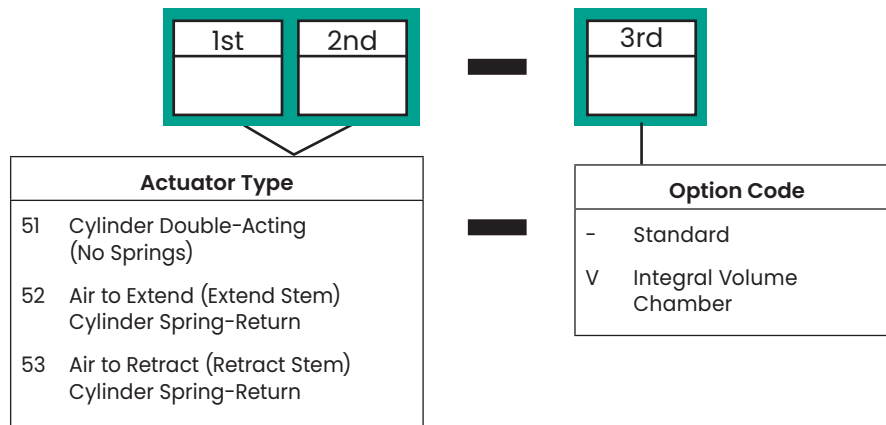

General Specifications

Model 51 - Double Acting

Actuator Size	Cylinder Dia in (mm)	Piston Type	Actuator Thrust (max)		Effective Piston Area			Maximum Stroke		Chamber Volume	
			N	Lb	Chamber	in ²	mm ²	in	mm	inch ³	m ³
12	12 (305)	Single	50960	11456	Upper	113	72800	4	101.6	989	0.0162
					Lower	112	72100				
16	15 (386)	Single	81830	18395	Upper	181	116900	6	152.4	1489	0.0244
					Lower	180	116000	12	304.8	-	-
20	19 (488)	Single	130830	19411	Upper	290	186900	6	152.4	2264	0.0371
					Lower	287	185400	12	304.8	-	-
24	15 (386)	Double	123066	27665	Upper	360	232200	12	304.8	-	-
					Lower	356	229700	-	-	-	-
28	19 (488)	Double	197266	44345	Upper	577	372200	12	304.8	-	-
					Lower	573	369700	-	-	-	-
32	23 (574)	Double	256750	57717	Upper	792	513500	12	304.8	-	-
					Lower	788	508400	-	-	-	-

52/53 Spring Return Design – Standard Actuator Sizes and Spring Ranges

Actuator Size	Effective Piston Area		Maximum Stroke		Standard Spring Ranges			
					Initial	Final	Initial	Final
	in ²	cm ²	in	mm	psi	psi	MPa	MPa
12	112	721	4	101.6	10	25	0.07	0.17
					20	40	0.14	0.28
					25	50	0.17	0.34
16	180	1160	2.5	63.5	10	25	0.07	0.17
					20	40	0.14	0.28
					25	50	0.17	0.34
			4	101.6	10	25	0.07	0.17
					20	40	0.14	0.28
					25	50	0.17	0.34
			6	152.4	10	25	0.07	0.17
					20	40	0.14	0.28
					25	50	0.17	0.34
20	287	1854	2.5	63.5	10	25	0.07	0.17
					20	40	0.14	0.28
					25	50	0.17	0.34
			4	101.6	10	25	0.07	0.17
					20	40	0.14	0.28
					25	50	0.17	0.34
			6	152.4	10	25	0.07	0.17
					20	40	0.14	0.28
					25	50	0.17	0.34

Notes: Standard Ambient Temperature Range: -4°F to +180°F (-20°C to +83°C).
 Maximum Supply Pressure: 150 psig (1.03 MPa).

Stem Travel Model 51

Actuator Size	Model 51 Actuator Stroke																	
	in	0.25	0.38	0.5	0.62	0.75	0.8	1	1.25	1.5	2	2.5	2.75	3	3.25	3.5	3.75	
	mm	6.4	9.7	12.7	15.7	19	20	25.4	31.8	38.1	50.8	63.5	69.9	76.2	82.5	88.9	95.3	
12	x	x	x	x	x	x	x	x	x	x	x	x	x	x	x	x	x	x
16	x	x	x	x	x	x	x	x	x	x	x	x	x	x	x	x	x	x
20	x	x	x	x	x	x	x	x	x	x	x	x	x	x	x	x	x	x
24	x	x	x	x	x	x	x	x	x	x	x	x	x	x	x	x	x	x
28	x	x	x	x	x	x	x	x	x	x	x	x	x	x	x	x	x	x
32	x	x	x	x	x	x	x	x	x	x	x	x	x	x	x	x	x	x

Actuator Size	Model 51 Actuator Stroke (cont.)																
	in	4	4.25	4.5	5	5.5	6	7	7.25	7.5	8	8.25	8.5	9	10	11	12
	mm	101.6	108	114.3	139.7	152.4	152.4	177.8	184.2	190.5	203.2	209.6	215.9	228.6	254	279.4	304.8
12	x	-	-	-	-	-	-	-	-	-	-	-	-	-	-	-	-
16	x	x	x	x	x	x	x	x	x	x	x	x	x	x	x	x	x
20	x	x	x	x	x	x	x	x	x	x	x	x	x	x	x	x	x
24	x	x	x	x	x	x	x	x	x	x	x	x	x	x	x	x	x
28	x	x	x	x	x	x	x	x	x	x	x	x	x	x	x	x	x
32	x	x	x	x	x	x	x	x	x	x	x	x	x	x	x	x	x

Stem Travel Model 52/53

Actuator Size	Model 52/53 Actuator Stroke																			
	in	.25	.38	.5	.62	.75	.8	1	1.25	1.5	2	2.25	2.5	3	3.5	3.75	4	5	5.5	6
	mm	6.4	9.7	12.7	15.7	19	20	25.4	31.8	38.1	50.8	57.2	63.5	76.2	88.9	95.3	101.6	139.7	152.4	152.4
12	-	-	-	-	-	-	-	-	-	-	-	-	-	x	x	x	x ¹	-	-	-
16	x	x	x	x	x	x	x	x	x	x	x	x	x ¹	x	x	x	x ¹	x	x	x ¹
20	x	x	x	x	x	x	x	x	x	x	x	x	x ¹	x	x	x	x ¹	x	x	x ¹

1. Indicates standard strokes for each actuator size.

Note: Optional actuator strokes are provided using standard springs. Resultant spring ranges are shown in the following tables.

General Specifications

Adjustable Travel Stops

Size	Model	Adjustable Stroke Range			
		Up Stop		Down Stop	
		Stroke in (mm)	Adjustable Valve Opening (%)	Stroke in (mm)	Adjustable Valve Opening (%)
12	51 ¹	2 (50.8)	50-100 @ 4 in. Travel	2 (50.8)	0-50 @ 4 in. Travel
16	51 ¹	3 (76.2)	50-100 @ 6 in. Travel	3 (76.2)	0-50 @ 6 in. Travel
20	51 ¹	3 (76.2)	50-100 @ 6 in. Travel	3 (76.2)	0-50 @ 6 in. Travel
12	52	2 (50.8)	50-100 @ 4 in. Travel	2 (50.8)	0-50 @ 4 in. Travel
16	52	3 (76.2)	50-100 @ 6 in. Travel	3 (76.2)	0-50 @ 6 in. Travel
20	52	3 (76.2)	50-100 @ 6 in. Travel	3 (76.2)	0-50 @ 6 in. Travel
12	53	2 (50.8)	50-100 @ 4 in. Travel	2 (50.8)	0-50 @ 4 in. Travel
16	53	3 (76.2)	50-100 @ 6 in. Travel	3 (76.2)	0-50 @ 6 in. Travel
20	53	3 (76.2)	50-100 @ 6 in. Travel	3 (76.2)	0-50 @ 6 in. Travel

1. Adjustable stopper is available only for option without volume chamber.

Note: Consult factory for range of adjustment for actuators with travel greater than 6 inch (152.4mm).

Adjustable travel stops are not available with volume chamber or hydraulic handjack.

Manual Override Options

Actuator Size	Actuator Model	Type / Mounting	Model Designation
12	51/52/53	Mechanical Handwheel / Side-Mounted	CM
16	51/52/53	Mechanical Handwheel / Side-Mounted	DM
20	51	Mechanical Handwheel / Side-Mounted	DM
20	52/53	Hydraulic Handjack / Top-Mounted	HH
24/28/32	51	Mechanical Handwheel / Side-Mounted	DM

Valve Mounting Interfaces

Standard Yoke Spud Diameter		Yoke Connection	Actuator Size					
inches	mm		12	16	20	24	28	32
2.25	57	Drive Nut	X	X	-	-	-	-
3.31	84	Drive Nut	X	X	X	-	-	-
3.75	95	Drive Nut	X	X	X	-	-	-
3.75	95	Bolted	-	X	X	-	-	-
5.00	127	Bolted	-	X	X	X	X	X

Stem Size		Actuator Size					
in	mm	12	16	20	24	28	32
0.50	12.7	X	X	-	-	-	-
0.63	15.9	X	X	X	-	-	-
0.75	19.1	X	X	X	-	-	-
1.00	25.4	X	X	X	X	X	X
1.13	28.6	X	X	X	X	X	X
1.25	31.8	-	X	X	X	X	X
1.50	38.1	-	X	X	X	X	X
1.63	41.3	-	-	-	X	X	X

Notes:

Split clamps are used for the valve stem to piston stem connections on all actuator sizes.

Split clamps also provide a mechanical anti-rotation feature in both automatic and manual operating mode.

General Specifications

Air Connections

	Size 12/16/20		Size 24/28		Size 32	
	Top & Yoke	Separator Plate	Top & Yoke	Separator Plate	Top & Yoke	Separator Plate
Standard	3/4NPT, Qty:1	1/2NPT,Qty:1	3/4NPT, Qty:1	1/2NPT, Qty:1	3/4NPT, Qty:2	3/4NPT, Qty:2
Option A	3/4NPT, Qty:2	1/2NPT, Qty:2	3/4NPT, Qty:2	1/2NPT, Qty:2	3/4NPT, Qty:3	3/4NPT, Qty:3
Option B (for size 12/16/20 without Volume Chamber)	1NPT, Qty:1	-	-	-	-	-
Option C (for size 12/16/20 without Volume Chamber)	1NPT, Qty:2	-	-	-	-	-

Optional Spring Ranges – Model 52 Air to Extend

Actuator Size	Actuator Stroke		Optional Spring Ranges				
	in	mm	Initial	Final	Initial	Final	
			psi	psi	MPa	MPa	
12	3.75	95.3	10	24	.07	.17	
			20	39	.14	.27	
			25	48	.17	.33	
	3.5	88.9	10	23	.07	.16	
			20	38	.14	.26	
			25	47	.17	.32	
	3	76.2	10	21	.07	.14	
			20	35	.14	.24	
			25	44	.17	.30	
16	5.5	139.7	10	24	.07	.17	
			20	38	.14	.26	
			25	48	.17	.33	
	5	127	10	23	.07	.16	
			20	37	.14	.26	
			25	46	.17	.32	
	3.75	95.3	10	24	.07	.17	
			20	39	.14	.27	
			25	48	.17	.33	
	3.5	88.9	10	23	.07	.16	
			20	38	.14	.26	
			25	47	.17	.32	
	3	76.2	10	21	.07	.14	
			20	35	.14	.24	
			25	44	.17	.30	
20	2.25	57.2	10	24	.07	.17	
			20	38	.14	.26	
			25	48	.17	.33	
	2	50.8	10	22	.07	.15	
			20	36	.14	.25	
			25	45	.17	.31	
	20	5.5	139.7	10	24	.07	.17
				20	38	.14	.26
				25	48	.17	.33
5		127	10	23	.07	.16	
			20	37	.14	.26	
			25	46	.17	.32	
3.75		95.25	10	24	.07	.17	
			20	39	.14	.27	
			25	48	.17	.33	
3.5		88.9	10	23	.07	.16	
			20	38	.14	.26	
			25	47	.17	.32	
3		76.2	10	21	.07	.14	
			20	35	.14	.24	
			25	44	.17	.30	
2.25	57.15	10	24	.07	.17		
		20	38	.14	.26		
		25	48	.17	.33		
2	50.8	10	22	.07	.15		
		20	36	.14	.25		
		25	45	.17	.31		

Optional Spring Ranges – Model 53 Air to Retract

Actuator Size	Actuator Stroke		Optional Spring Ranges			
	in	mm	Initial	Final	Initial	Final
			psi	psi	MPa	MPa
12	3.75	95.3	11	25	.08	.17
			21	40	.14	.28
			27	50	.19	.34
	3.5	88.9	12	25	.08	.17
			22	40	.15	.28
			28	50	.19	.34
	3	76.2	14	25	.10	.17
			25	40	.17	.28
			31	50	.21	.34
16	5.5	139.7	11	25	.08	.17
			22	40	.15	.28
			27	50	.19	.34
	5	127	12	25	.08	.17
			23	40	.14	.28
			29	50	.20	.34
	3.75	95.3	11	25	.08	.17
			21	40	.14	.28
			27	50	.19	.34
	3.5	88.9	12	25	.08	.17
			22	40	.15	.28
			28	50	.19	.34
	3	76.2	14	25	.10	.17
			25	40	.17	.28
			31	50	.21	.34
2.25	57.2	11	25	.08	.17	
		22	40	.15	.28	
		27	50	.19	.34	
2	50.8	13	25	.09	.17	
		24	40	.17	.28	
		30	50	.21	.34	
20	5.5	139.7	11	25	.08	.17
			22	40	.15	.28
			27	50	.19	.34
	5	127	12	25	.08	.17
			23	40	.14	.28
			29	50	.20	.34
	3.75	95.25	11	25	.08	.17
			21	40	.14	.28
			27	50	.19	.34
	3.5	88.9	12	25	.08	.17
			22	40	.15	.28
			28	50	.19	.34
	3	76.2	14	25	.10	.17
			25	40	.17	.28
			31	50	.21	.34
2.25	57.15	11	25	.08	.17	
		22	40	.15	.28	
		27	50	.19	.34	
2	50.8	13	25	.09	.17	
		24	40	.17	.28	
		30	50	.21	.34	

Materials of Construction

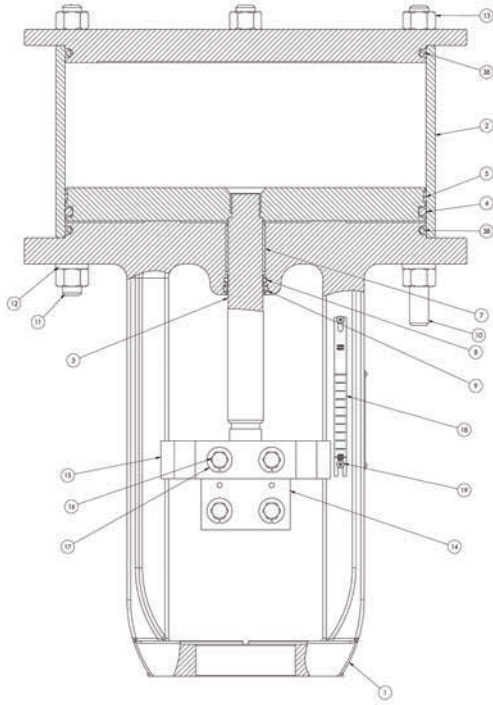

Model 51 Double Acting
Without Handwheel, without Volume Chamber

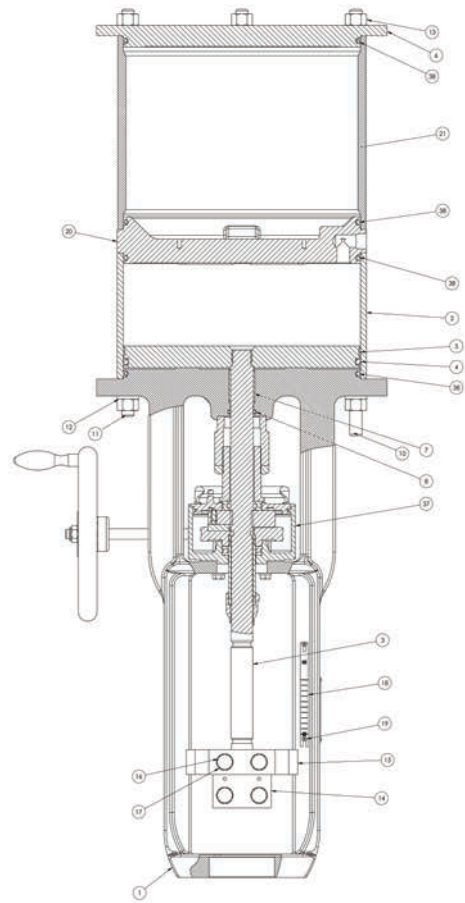

Model 51 Double Acting
With Handwheel, with Volume Chamber

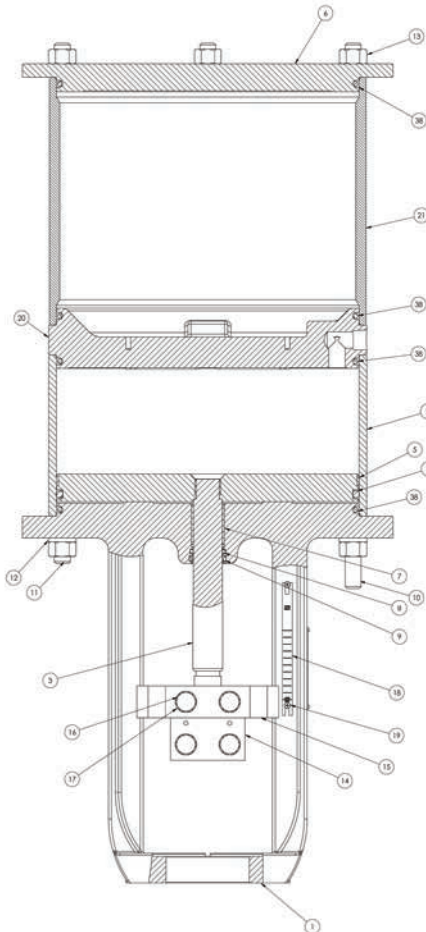

Model 51 Double Acting
Without Handwheel, with Volume Chamber

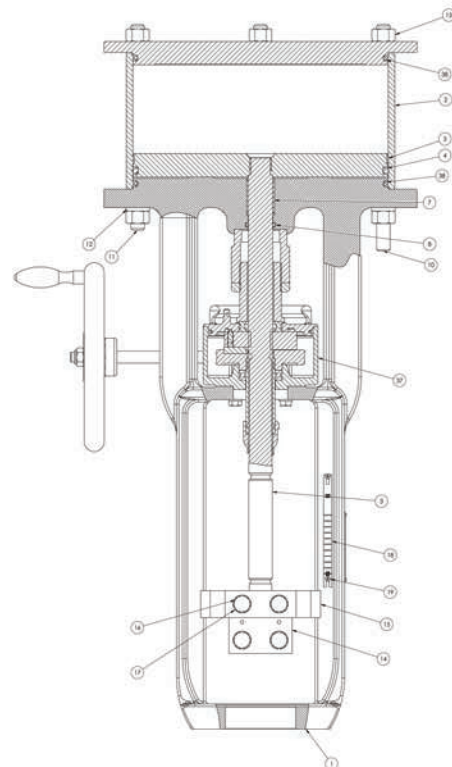

Model 51 Double Acting
With Handwheel, without Volume Chamber

Standard Construction

Model 51 Double-Acting Design

Ref. No.	Description	Standard Materials -20°C to +100°C (-4°F to +212°F)
1	Yoke	Ductile Iron ¹
2	Cylinder tube	Carbon Steel, Chrome Plated ID
3	Piston S/A	
	Piston rod	17-4 PH Stainless Steel H1075 or Equivalent
	Piston	Carbon Steel
4	O-ring	Nitrile (Buna-N)
5	Guide ring	Graphite / Teflon
6	Top plate	Carbon Steel
7	Guide bushing	PTFE/Steel
8	O-ring	Nitrile (Buna-N)
9	Rod scraper	Nitrile (Buna-N)
10	Standard center bolt	Alloy Steel
11	Extended center bolt	Alloy Steel
12	Spring lock washer	Carbon Steel (Zinc-Plated with Black Oxide Finish)
13	Hexagon nut	Carbon Steel (Zinc-Plated with Black Oxide Finish)
14	Split clamp	Carbon Steel (Black Oxide Finish)
15	Indicator arm	Carbon Steel
16	Hexagon bolt	Carbon Steel (Zinc-Plated with Black Oxide Finish)
17	Spring lock washer	Carbon Steel (Zinc-Plated with Black Oxide Finish)
18	Indicator plate	Stainless Steel
19	Indicator plate screw	Stainless Steel
20	Separator plate ²	Ductile Iron
21	Volume chamber tube ²	Carbon Steel (with Black Oxide Finish)
37	CM Handwheel Assembly	Steel
	DM Handwheel Assembly	Steel
38	O-ring	Nitrile (Buna-N)

1. Yoke material for size 32 is carbon steel.

2. These are additional components only required for the integral volume tank design.

Materials of Construction

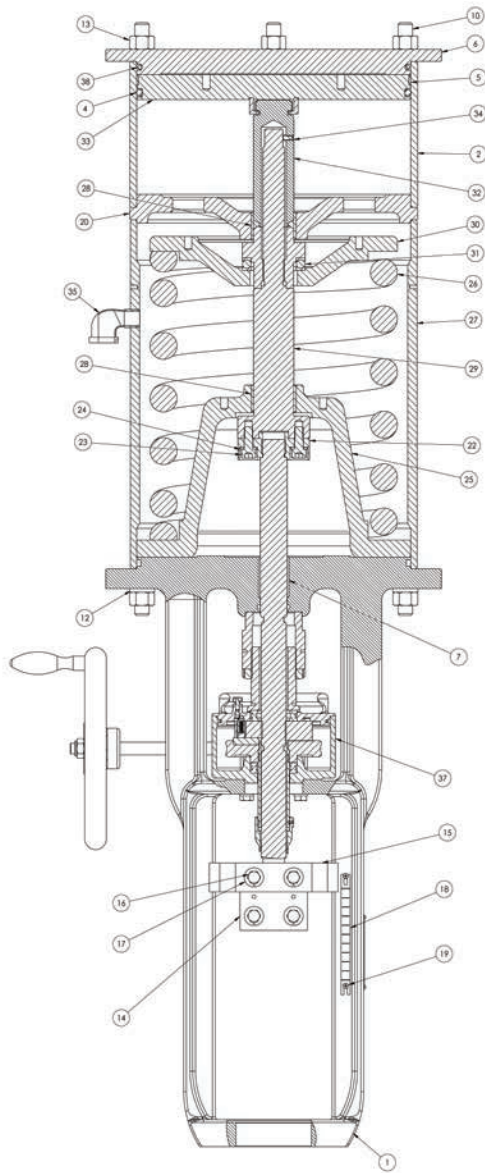

Model 52
Air to extend with Handwheel

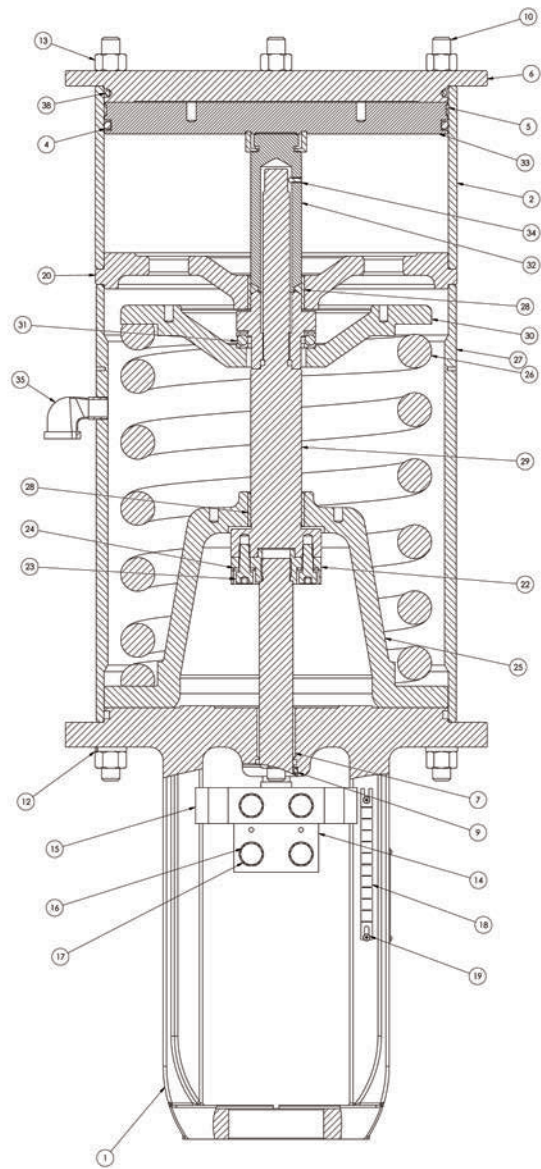

Model 52
Air to extend without Handwheel

Standard Construction

Model 52 Air to Extend with Spring Return

Ref. No.	Description	Standard Materials -20°C to +100°C (-4°F to +212°F)
1	Yoke	Ductile Iron
2	Cylinder tube	Carbon Steel, Chrome Plated ID
4	O-ring	Nitrile (Buna-N)
5	Guide ring	Graphite / Teflon
6	Top plate	Carbon Steel
7	Guide bushing	PTFE/Steel
8	O-ring	Nitrile (Buna-N)
9	Rod scraper	Nitrile (Buna-N)
10	Center bolt	Alloy Steel
12	Spring lock washer	Carbon Steel (Zinc-Plated with Black Oxide Finish)
13	Hexagon nut	Carbon Steel (Zinc-Plated with Black Oxide Finish)
14	Split clamp	Carbon Steel (Black Oxide Finish)
15	Indicator arm	Carbon Steel
16	Hexagon bolt	Carbon Steel (Zinc-Plated with Black Oxide Finish)
17	Spring lock washer	Carbon Steel (Zinc-Plated with Black Oxide Finish)
18	Indicator plate	Stainless Steel
19	Indicator plate screw	Stainless Steel
20	Separator plate	Ductile Iron
22	Piston rod S/A	
	Piston rod	17-4 PH Stainless Steel H1075 or Equivalent
	Piston rod (Handwheel)	17-4 PH Stainless Steel H1075 or Equivalent
	Rod joint	Carbon Steel
23	Hexagon socket head cap screw	Alloy Steel (Zinc Plated)
24	Spring lock washer	Carbon Steel (Zinc-Plated)
25	Lower spring button	Cast Iron
26	Spring	Alloy Steel
27	Spring tube	Carbon Steel
28	Guide bushing	PTFE/Steel
29	Compression bolt	Carbon Steel
30	Upper spring button	Ductile Iron
31	Thrust bearing	Chrome-Alloy Steel
32	Compression nut	Stainless Steel
33	Piston plate S/A	
	Piston	Carbon Steel
	Stop collar	Carbon Steel
34	Set screw	Stainless Steel
35	Exhaust pipe	Carbon Steel (Zinc-Plated)
37	CM Handwheel Assembly	Steel
	DM Handwheel Assembly	Steel
38	O-ring	Nitrile (Buna-N)

Materials of Construction

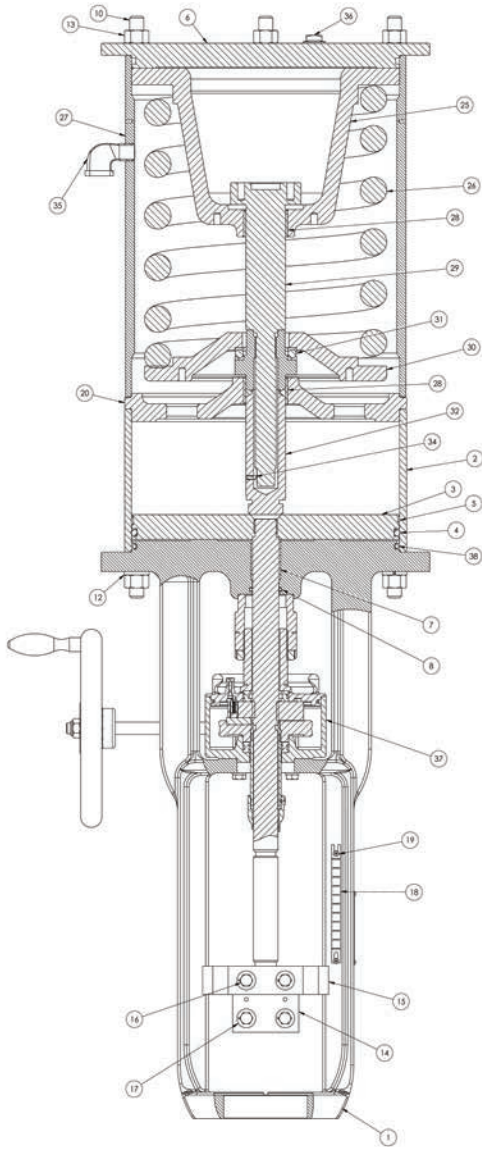

Model 53
Air to retract with Handwheel

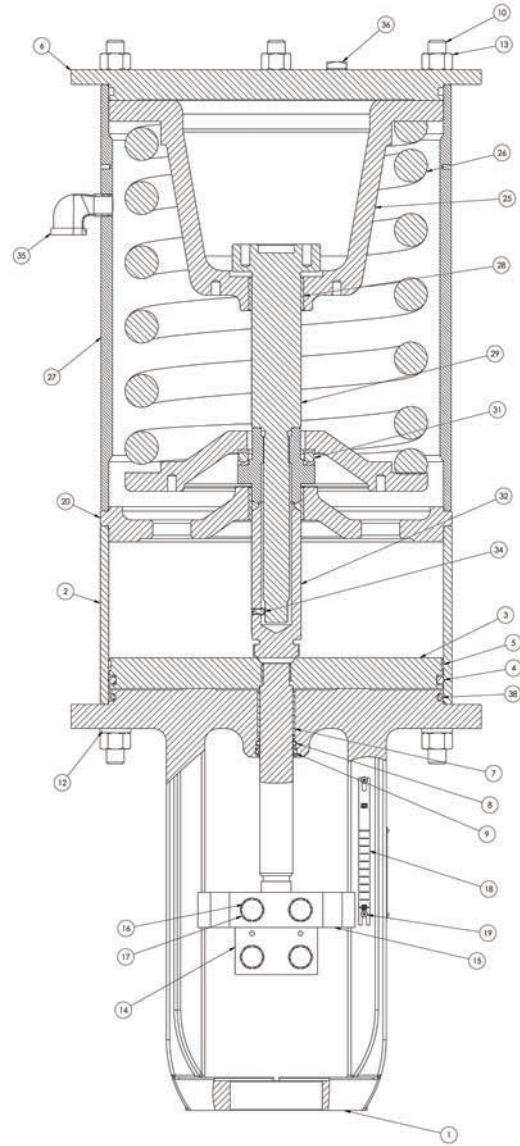

Model 53
Air to retract without Handwheel

Standard Construction

Model 53 Air to Retract with Spring Return

Ref. No.	Description	Standard Materials -4°F to +212°F (-20°C to +100°C)
1	Yoke	Ductile Iron
2	Cylinder tube	Carbon Steel, Chrome Plated ID
3	Piston S/A	
	Piston rod	17-4 PH Stainless Steel H1075 or Equivalent
	Piston	Carbon Steel
4	O-ring	Nitrile (Buna-N)
5	Guide ring	Graphite / Teflon
6	Top plate	Carbon Steel
7	Guide bushing	PTFE/Steel
8	O-ring	Nitrile (Buna-N)
9	Rod scraper	Nitrile (Buna-N)
10	Center bolt	Alloy Steel
12	Spring lock washer	Carbon Steel (Zinc-Plated with Black Oxide Finish)
13	Hexagon nut	Carbon Steel (Zinc-Plated with Black Oxide Finish)
14	Split clamp	Carbon Steel (Black Oxide Finish)
15	Indicator arm	Carbon Steel
16	Hexagon bolt	Carbon Steel (Black Oxide Finish)
17	Spring lock washer	Carbon Steel (Zinc-Plated with Black Oxide Finish)
18	Indicator plate	Stainless Steel
19	Indicator plate screw	Stainless Steel
20	Separator plate	Ductile Iron
25	Upper spring button	Cast Iron
26	Spring	Alloy Steel
27	Spring tube	Carbon Steel
28	Guide bushing	PTFE/Steel
29	Compression bolt	Carbon Steel
30	Lower spring button	Ductile Iron
31	Thrust bearing	Chrome-Alloy Steel
32	Compression nut	Stainless Steel
34	Set screw	Stainless Steel
35	Exhaust pipe	Carbon Steel (Zinc-Plated)
36	Plug	Carbon Steel (Zinc-Plated)
37	CM Handwheel Assembly	Steel
	DM Handwheel Assembly	Steel
38	O-ring	Nitrile (Buna-N)

Optional Constructions

Low-Temperature Service: Suitable for low ambient temperature

Ref. No.	Description	Low Temp. Construction -50°F to +181°F (-46°C to +83°C)
1	Yoke	Low Carbon Steel
4	O-ring	Nitrile – Low Temperature
2, 3, 6, 21, 51DP, 55DP, 56DP	Top plate, Piston, Cylinder, Volume Chamber	Low Carbon Steel
8	O-ring	Nitrile – Low Temperature
9	Rod scraper	Nitrile – Low Temperature
10, 11	Center Bolt	Stainless Steel
13	Hex Nut	Stainless Steel
20, 49DP	Separator plate	Low Carbon Steel
4, 8, 9, 38, 136, 54DP, 103	O-ring	Nitrile – Low Temperature
9	Rock Scraper	Nitrile – Low Temperature

Ref. No.	Description	Low Temp. Construction -58°F to +181°F (-50°C to +83°C)
1	Yoke	Low Carbon Steel (Stainless Steel for size 32)
4	O-ring	Nitrile – Low Temperature
2, 3, 6, 21, 51DP, 55DP, 56DP	Top plate, Piston, Cylinder, Volume Chamber	Stainless Steel
8	O-ring	Nitrile – Low Temperature
9	Rod scraper	Nitrile – Low Temperature
10, 11	Center Bolt	Stainless Steel
13	Hex Nut	Stainless Steel
20	Separator plate	Low Carbon Steel
49DP	Separator plate	Stainless Steel
4, 8, 9, 38, 136, 54DP, 103	O-ring	Nitrile – Low Temperature
9	Rock Scraper	Nitrile – Low Temperature

Note: The above indicates only those parts that change material for low temperature service. All other parts remain the same as standard.

High-Temperature Service: Suitable for high ambient temperature

Ref. No.	Description	High Temperature Construction -4°F to +212°F (-20°C to +100°)
4	O-ring	Nitrile – High Temperature
8	O-ring	Nitrile – High Temperature
38	O-ring	Nitrile – High Temperature

Note: The above indicates only those parts that change material for high temperature service. All other parts remain the same as standard.

Integral Volume Tanks

The Model 51 Double-Acting Actuator without springs is also available with integral volume tanks for emergency fail action. Key advantages of the integrated volume tank design include sealing integrity and a reduced number of components. Standard sizes are shown in the chart below. Consult the factory for proper selection to meet the specific application requirements.

Actuator Size	Volume Tank Size	
	Gallons (US)	Liters
12	4.3	16.2
16	6.5	24.4
20	9.8	37.1

Adjustable Travel Stops

Item No.	Part Name	STD Material (PED)
100-1	Top plate	Carbon steel
100-2	Stopper boss	ASTM A36
101	Stop bolt	Stainless steel
103	O-ring	Nitrile (Buna-N)
104	Hexagon nut	Carbon steel
106	Hexagon bolt	Stainless steel
107	Hexagon nut	Carbon steel
109-1	Piston	ASTM A105 Per PMA MN0023
109-2a	Piston rod	17-4 PH Stainless steel
109-2b	Piston rod (Handwheel)	17-4 PH Stainless Steel
110	Stop collar	Carbon steel

Stainless Steel Bolting

Item No.	Part Name	STD Material
10 & 11	Center bolt	Stainless steel
13	Hexagon nut	Stainless steel
16	Hexagon bolt	Stainless steel
133	Hexagon bolt	Stainless steel
134	Hexagon nut	Stainless steel
135	Stud bolt	Stainless steel

Steel Yoke

Item No.	Part Name	STD Material
1	Yoke	Carbon steel LCC

Dimensions

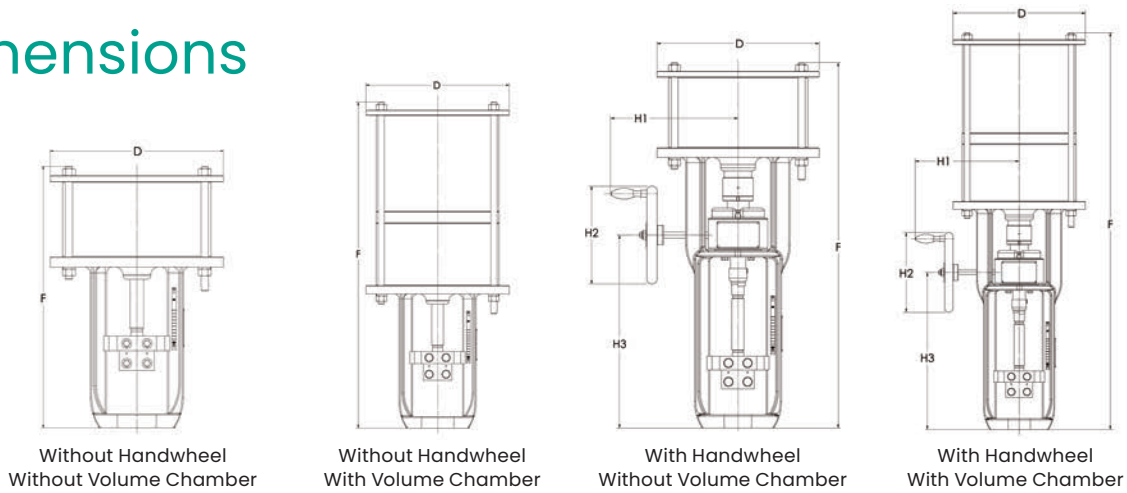

Model 51 Dimensional Data

Inches (mm)

Size	D	H1	H2	H3
12	14.7 (373)	11.5 (292)	8.9 (225)	17.4 (443)
16	18.1 (461)	13.4 (340)	11 (280)	21.7 (553)
20	22.6 (573)	13.4 (340)	11 (280)	22.1 (563)
24	18.1 (461)	13.4 (340)	11 (280)	22.1 (563)
28	22.6 (573)	13.4 (340)	11 (280)	22.1 (563)
32	26.4 (670)	13.4 (340)	11 (280)	22.2 (564)

Actuator Type	Actuator Size	Dimension F inches (mm)					
		Nominal Actuator Travel inches (mm)					
		2.5 (63.5)	4 (101.6)	6 (152.4)	8 (203.2)	10 (254)	12 (304.8)
Standard	12	-	23.0 (584)	-	-	-	-
	16	24.7 (628)	26.2 (666)	28.2 (717)	36.2 (920)	38.2 (971)	42.2 (1073)
	20	25.4 (645)	26.9 (683)	28.9 (734)	36.7 (931)	38.7 (982)	45.0 (1142)
	24	33.1 (842)	36.1 (918)	40.1 (1020)	48.1 (123)	52.1 (1324)	60.2 (1528)
	28	34.3 (870)	37.3 (946)	52.2 (1326)	49.3 (1251)	53.3 (1353)	61.3 (1556)
	32	42.7 (1085)	45.7 (1161)	49.7 (1262)	57.8 (1467)	61.8 (1569)	69.8 (1773)
Standard with Integral Volume Tank	12	-	34.0 (864)	-	-	-	-
	16	35.8 (908)	37.3 (946)	39.3 (997)	-	-	-
	20	36.0 (915)	37.5 (953)	39.5 (1004)	-	-	-
Standard with Handwheel	12	-	33.7 (857)	-	-	-	-
	16	40.6 (1031)	42.1 (1069)	44.1 (1119)	59.3 (1506)	61.3 (1557)	69.3 (1760)
	20	41.2 (1048)	42.7 (1086)	44.7 (1136)	59.6 (1513)	61.6 (1564)	69.6 (1767)
	24	48.2 (1224)	51.2 (1301)	55.2 (1402)	71.2 (1808)	75.2 (1910)	85.2 (2164)
	28	49.2 (1249)	52.2 (1326)	53.2 (1427)	72.1 (1831)	76.1 (1933)	86.1 (2187)
	32	56.6 (1440)	59.7 (1516)	63.7 (1617)	79.7 (2025)	83.7 (2126)	93.7 (2381)
Standard with Integral Volume Tank and Handwheel	12	-	44.8 (1137)	-	-	-	-
	16	51.6 (1311)	53.1 (1349)	55.1 (1399)	-	-	-
	20	51.9 (1318)	53.4 (1356)	55.4 (1406)	-	-	-

Dimensions

Model 52 and 53 Dimensional Data

Inches (mm)

Size	D	H1	H2	H3
12	14.69 (373)	11.50 (292)	8.86 (225)	17.44 (443)
16	18.15 (461)	13.39 (340)	11.02 (280)	21.77 (553)
20	22.56 (573)	13.39 (340)	11.02 (280)	22.17 (563)

Actuator Type	Actuator Size	Dimension F in (mm)		
		Nominal Actuator Travel In. (mm)		
		2.5 (63.5)	4 (101.6)	6 (152.4)
Standard	12	-	39.1 (993.8)	-
	16	39.5 (1003)	44 (1117)	50 (1269)
	20	41.1 (1045)	45.6 (1159)	51.6 (1311)
Standard with Handwheel	12	-	49.9 (1267)	-
	16	55.3 (1406)	59.8 (1520)	65.8 (1671)
	20	64.6 (1642)	69.1 (1756)	75.1 (1908)

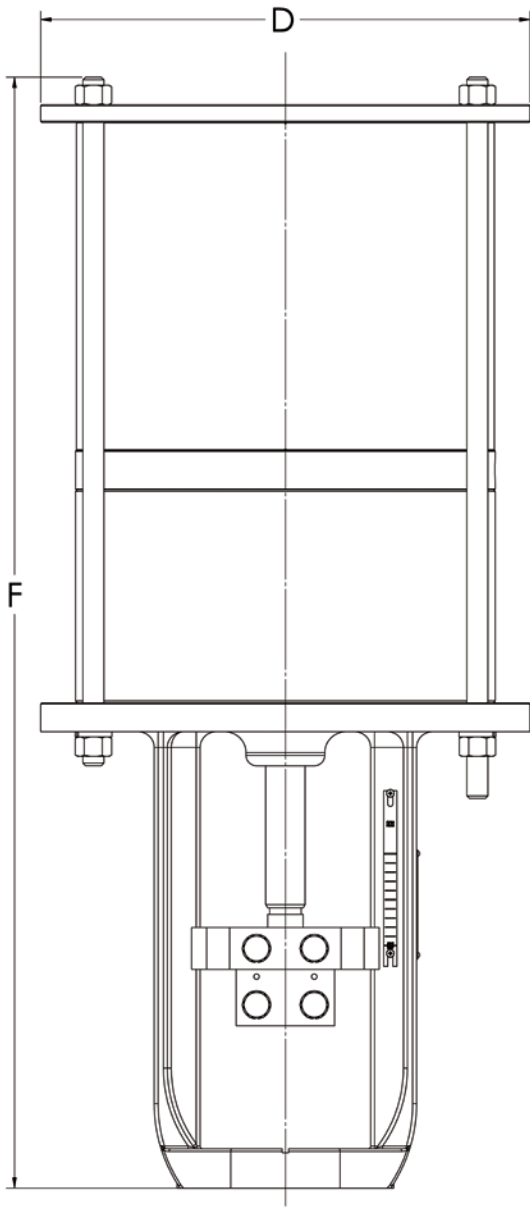

Without Handwheel

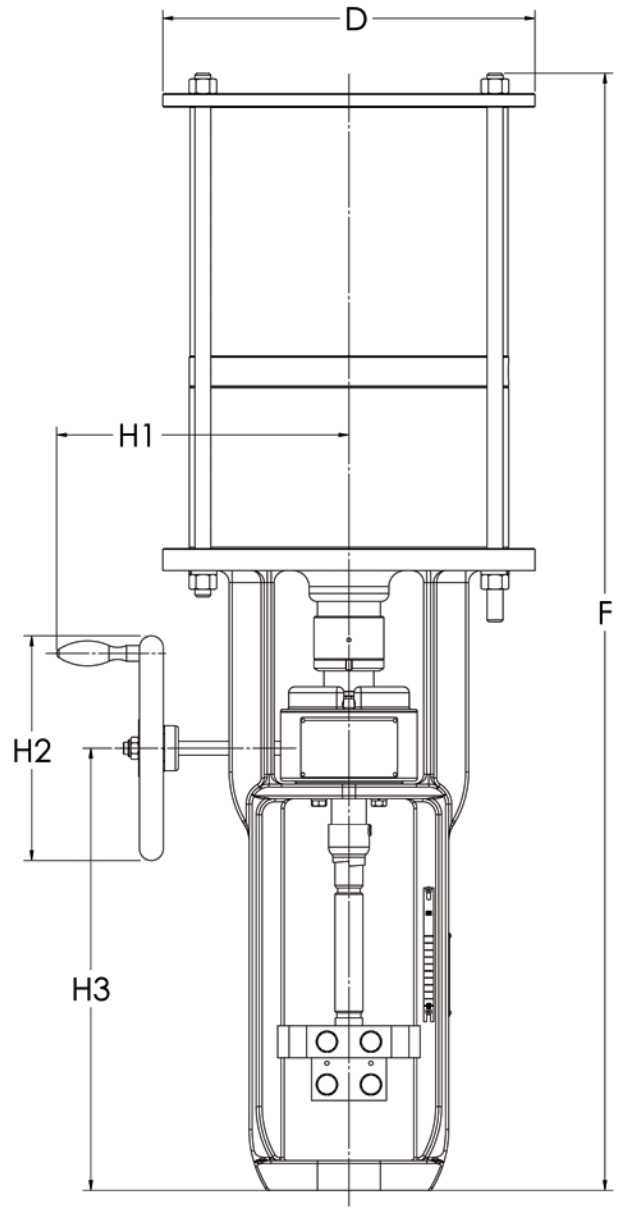

With Handwheel

Weights

In US Units (lbs)

Actuator Size	Construction	Nominal Stroke in (mm)	Model 51		Model 52		Model 53	
			Without Handwheel	With Handwheel	Without Handwheel	With Handwheel	Without Handwheel	With Handwheel
12	Standard	4 (101.6)	179	227	412	456	410	454
	with Integral Volume Chamber	4 (101.6)	280	328	-	-	-	-
16	Standard	2.5 (63.5)	386	529	712	853	703	849
		4 (101.6)	386	529	761	902	754	897
		6 (152.4)	386	529	864	1005	855	1001
		10 (254)	465	628	-	-	-	-
		12 (304.8)	500	688	-	-	-	-
	with Integral Volume Chamber	2.5 (63.5)	578	721	-	-	-	-
		4 (101.6)	578	721	-	-	-	-
		6 (152.4)	578	721	-	-	-	-
		10 (254)	465	628	-	-	-	-
		12 (304.8)	500	688	-	-	-	-
20	Standard	2.5 (63.5)	639	785	1157	1303	1149	1294
		4 (101.6)	639	785	1261	1407	1252	1398
		6 (152.4)	639	785	1387	1532	1378	1523
		10 (254)	699	849	-	-	-	-
		12 (304.8)	741	919	-	-	-	-
	with Integral Volume Chamber	2.5 (63.5)	919	1065	-	-	-	-
		4 (101.6)	919	1065	-	-	-	-
		6 (152.4)	919	1065	-	-	-	-
		10 (254)	699	849	-	-	-	-
		12 (304.8)	741	919	-	-	-	-
24	Standard	6 (152.4)	714	970	-	-	-	-
		10 (254)	791	1109	-	-	-	-
		12 (304.8)	838	1177	-	-	-	-
28	Standard	6 (152.4)	1190	1362	-	-	-	-
		10 (254)	1305	1506	-	-	-	-
		12 (304.8)	1369	1579	-	-	-	-
32	Standard	6 (152.4)	2116	2299	-	-	-	-
		10 (254)	2235	2449	-	-	-	-
		12 (304.8)	2304	2522	-	-	-	-

Weights

In Metric Units (kg)

Actuator Size	Construction	Nominal Stroke in (mm)	Model 51		Model 52		Model 53	
			Without Handwheel	With Handwheel	Without Handwheel	With Handwheel	Without Handwheel	With Handwheel
12	Standard	4 (102)	81	103	187	207	186	206
	with Integral Volume Chamber	4 (102)	127	149	-	-	-	-
16	Standard	2.5 (64)	175	240	323	387	319	385
		4 (102)	175	240	345	409	342	407
		6 (152)	175	240	392	456	388	454
		10 (254)	211	285	-	-	-	-
		12 (305)	227	312	-	-	-	-
	with Integral Volume Chamber	2.5 (64)	262	327	-	-	-	-
		4 (102)	262	327	-	-	-	-
		6 (152)	262	327	-	-	-	-
		10 (254)	211	285	-	-	-	-
		12 (305)	227	312	-	-	-	-
20	Standard	2.5 (64)	290	356	525	591	521	587
		4 (102)	290	356	572	638	568	634
		6 (152)	290	356	629	695	625	691
		10 (254)	317	385	-	-	-	-
		12 (305)	336	417	-	-	-	-
	with Integral Volume Chamber	2.5 (64)	417	483	-	-	-	-
		4 (102)	417	483	-	-	-	-
		6 (152)	417	483	-	-	-	-
		10 (254)	317	385	-	-	-	-
		12 (305)	336	417	-	-	-	-
24	Standard	6 (152)	324	440	-	-	-	-
		10 (254)	359	503	-	-	-	-
		12 (305)	380	534	-	-	-	-
28	Standard	6 (152)	540	618	-	-	-	-
		10 (254)	592	683	-	-	-	-
		12 (305)	621	716	-	-	-	-
32	Standard	6 (152)	960	1043	-	-	-	-
		10 (254)	1014	1111	-	-	-	-
		12 (305)	1045	1144	-	-	-	-

Find the nearest local Channel Partner in your area:

valves.bakerhughes.com/contact-us

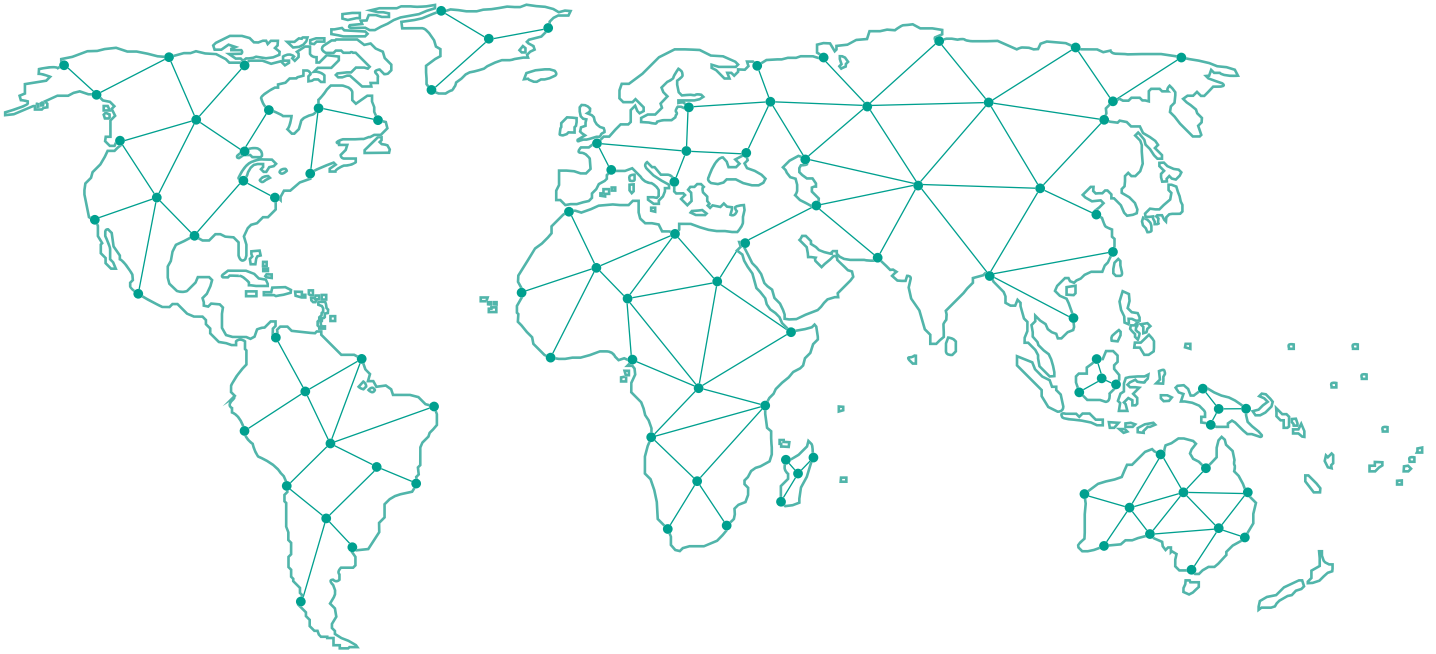

Tech Field Support & Warranty:

Phone: +1-866-827-5378
valvesupport@bakerhughes.com

valves.bakerhughes.com

Copyright 2023 Baker Hughes Company. All rights reserved. Baker Hughes provides this information on an "as is" basis for general information purposes. Baker Hughes does not make any representation as to the accuracy or completeness of the information and makes no warranties of any kind, specific, implied or oral, to the fullest extent permissible by law, including those of merchantability and fitness for a particular purpose or use. Baker Hughes hereby disclaims any and all liability for any direct, indirect, consequential or special damages, claims for lost profits, or third party claims arising from the use of the information, whether a claim is asserted in contract, tort, or otherwise. Baker Hughes reserves the right to make changes in specifications and features shown herein, or discontinue the product described at any time without notice or obligation. Contact your Baker Hughes representative for the most current information. The Baker Hughes logo and Masoneilan are trademarks of Baker Hughes Company. Other company names and product names used in this document are the registered trademarks or trademarks of their respective owners.

Baker Hughes 