

# Consolidated™ Pressure Relief Valves for Power Service

Pressure relief solutions for the power industry

- Safety Relief Valves
- Safety Valves



**Consolidated**  
a Baker Hughes business



Design and Performance that  
Meets Customer needs

# Safety, Quality, Support Equal Dependability

## Keeping People and Equipment Safe

For over 130 years, Consolidated has worked closely with our customers and regulatory organizations to configure, engineer, and manufacture a comprehensive portfolio of safety valves that help maintain safe, smooth and cost-effective operating conditions in demanding real-world power industry applications.

Steam service environments are a case in point. Consolidated safety valves from BHGE feature pop-action release that can relieve steam over-pressurization if pressures reach the valves' set point.

What's more, Consolidated safety valves comply with many certifications, including ASME B&PVC Section I code for boiler applications. For example, all models feature a lifting lever required by the code for testing instead of a deadweight or weighted lever.

Plus, tight tolerancing ensures Consolidated safety valves are at full lift at 103 percent of set pressure and quickly close when pressures reach 4 percent below the set pressure.

Our commitment to safe and efficient boiler operation is evidenced by our contributions to international organizations advancing pressure relief valve technology like the ASME B&PVC, IBR and ISO.

## Certified Quality

We adhere to strict manufacturing, testing and regulatory standards controlled by an ASME B&PVC-approved Quality Assurance Program, and we hold an ISO 9001 Quality System Certification. Additionally, our Quality Management System and Design Control procedures uphold stringent design criteria and require thorough testing for functional performance.

Once a valve passes the final test, we attach the Consolidated **Green Tag**™ symbol to show that it meets or exceeds requirements, including ASME B&PVC specifications. Our customers can feel confident that their crucial safety functions are supported by high quality products.



# Consolidated Safety Valves

## Expert Technical Support throughout the Product Life Cycle

We complement the excellent engineering and expertise behind every valve we make with knowledgeable sales guidance and reliable support services to help maintain safer operations for your people and your facility. Our worldwide sales force is factory-trained to offer consultation in valve sizing and selection to solve your specific challenges. Consolidated valve experts use their extensive pressure valve experience to seek the best fit for your budget and operational requirements with valves offering:

- Customized selections based on price, performance and cost of ownership
- Expert alternate recommendations that can save you money
- Safety-minded systems engineered with our extensive knowledge of codes, applications and service conditions
- Safety valve requirement validation for greater peace-of-mind
- Expert application evaluation to anticipate possible system problems and help improve operational earnings
- Experienced project management focused on your satisfaction, from bid request through shipment and startup

Support comes from our trained field service technicians who handle installations, startups, retrofits, upgrades and onsite emergencies worldwide. Our Green Tag Centers (GTC) provide fully certified assembly and repair services so customers can find the right resource to keep their valve equipment operating at high performance.

### Improving Turbine Operating Efficiency

*"A power plant was experiencing frequent failure rates with Pressure Relief Valves installed to protect turbine gland seals from overpressure."*

"Since the implementation, Consolidated's 2900 Series POSRV has performed flawlessly allowing the plant to operate more efficiently."

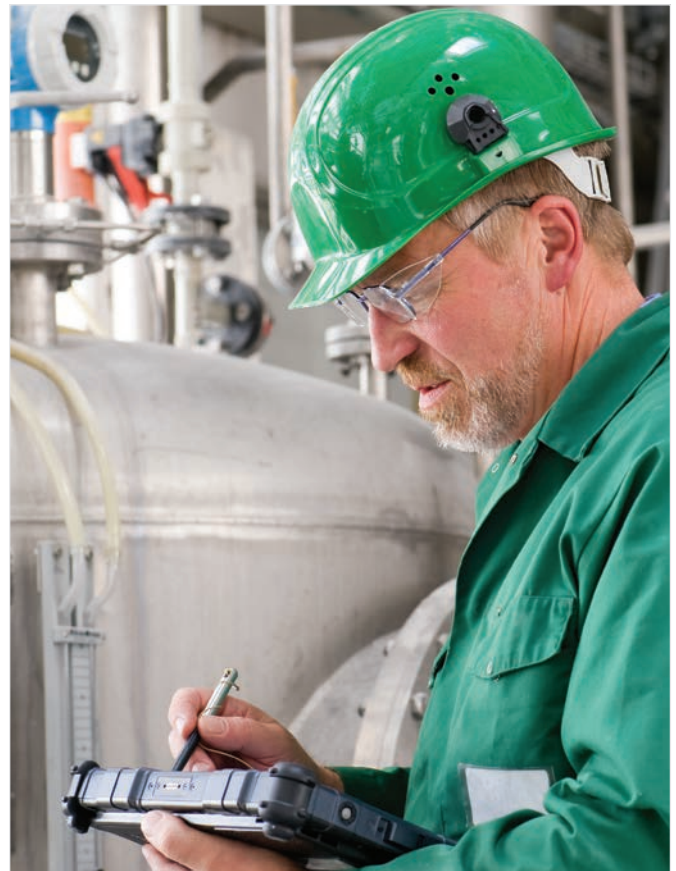

# Complete Green Tag Coverage

## We're Right at Your Doorstep!

We bring reliable valve services to your doorstep through our worldwide Green Tag certified valve assemblers and repair centers. Our authorized Green Tag Centers have successfully served the valve marketplace for more than 25 years. Our services include:

### Valve Survey

- Comprehensive and accurate record of all pressure relief valve service
- Identification of overlooked valves and valve interchangeability
- Product upgrades to reduce cost and improve performance

### Inspection of the Valve and Installation

- Evaluation of the installation for compliance to codes and regulations
- Written evaluation covering compliance issues and discrepancies
- Expert recommendations and corrective actions

### Testing

- Onsite and in-place testing using the
- Consolidated **EVT™** PRO testing device
- High-capacity shop testing with steam, air or water
- Fully trained and certified pressure relief valve technicians
- Base-line history establishment

### Repair

- Audited facility with Consolidated inspection criteria and critical dimensions
- Highly trained and certified pressure relief valve technicians
- Original manufacturer replacement parts

### Inventory Control

- Global access to spare parts inventories
- Parts interchangeability
- Obsolete and excess inventory identification
- Recommended cost-effective inventories

### ValvKeep™ Asset Management

- Comprehensive computer-based valve management service
- Historical data storage and permanent record tracking
- Maintenance scheduling and planning
- Repair intervals validated by maintenance history of each valve
- Code compliance
- Interfaces easily with enterprise or legacy systems

### Other Services

Training, sales and engineering support



# Consolidated Safety Valve Applications

## Boiler Safety Valves – Fired Pressure Vessel ASME B&PVC Section I

Taking into account a variety of important factors, our valve experts can help determine the right pressure relief valve solutions for your power and energy applications:

### Drum, Superheater & Reheater Safety Valves

- Blowdown requirements
- Seat-tightness requirement for low set valves
- Effects of high temperature, both service and ambient
- Maintenance requirements and features of the valve type selected

### Power-Actuated Relief Valves

- Number of cycles the valve can be expected to operate before failure
- Preventing chatter through proper sizing of the total boiler set

### Economizer Safety Relief Valves

- Code requirements
- Design of the installation and operating procedures

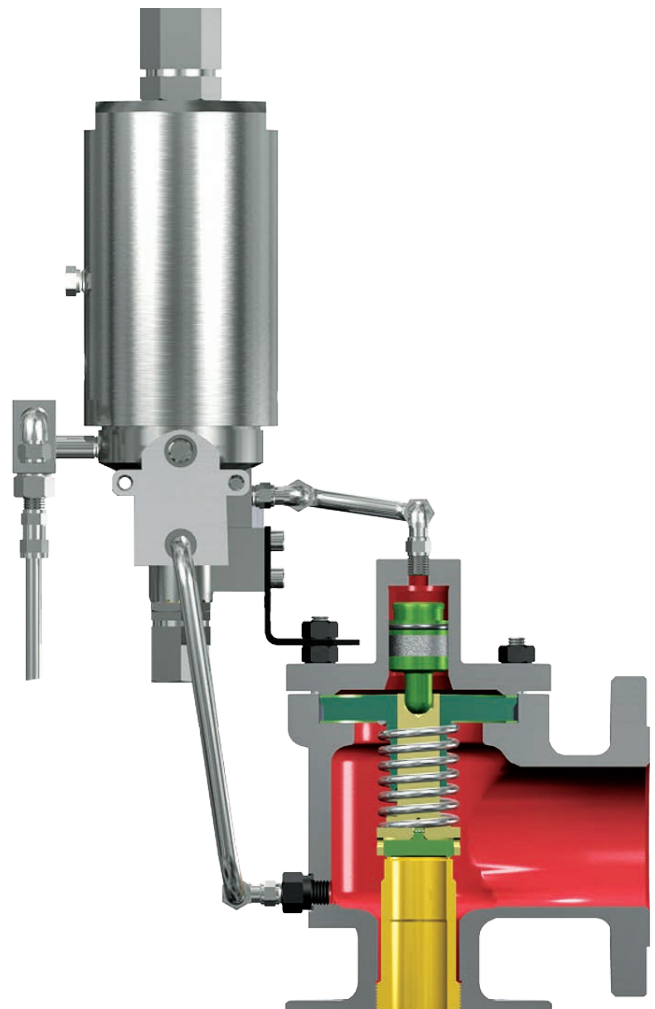

2900-40 Series  
Pilot Operated Safety Valve

# Consolidated Pressure Relief Valves

## The Right Safety Valve Solutions for Your Applications

### **Maxiflow™ 1700 and 2700 Series Safety Valves**

Max. Pressure: 5360 psig (369 barg)

Max. Temperature: 1120°F (604°C)

- Superb performance and stable, trouble-free boiler operation
- Repeatable seat tightness and extreme temperature compensation for safer operation and reduced down time
- Helps to save costs thanks to high allowable back-pressure limits when sizing the discharge stack and silencer
- 100 percent repairable and restorable design lowers cost of ownership throughout its lifespan
- A large installed base estimated to be more than 80 percent on Utility Power Boilers combined with the Green Tag network allows for local expertise and a large support inventory

### **1541, 1543, 1511 and 1811 Series Safety Valves**

Max. Pressure: 725 psig (49 barg)

Max. Temperature: 1000°F (538°C)

- Rugged and reliable valves recognized as some of the finest in the industry
- Inexpensive and easy to maintain with a low number of parts, reducing outage and inventory costs
- High-capacity discharge for excellent performance and valve number reduction

### **2900-40 Series Pilot Operated Safety Relief Valve**

Max. Pressure: 5800 psig (400 barg)

Max. Temperature: 1200°F (649°C) with heat exchanger

- Designed for economizer and organic vapor service
- Certified in accordance with ASME B&PVC Code Case 2446
- Superior performance with shorter blowdowns and operation at higher pressures
- Certified on steam and water

### **2900 Series Liquid Certified Pilot Operated Safety Relief Valve**

Max. Pressure: 6250 psig (431 barg)

Max. Temperature: 1200°F (649°C)

- Designed for liquid economizer and thermal fluid heater service
- Superior performance with shorter blowdown and operation at higher pressures
- Certified on water for ASME B&PVC Section I

### **1900 Series Liquid Certified Safety Relief Valve**

Max. Pressure: 6250 (431 barg)

Max. Temperature: 1500°F (815°C)

- Designed for liquid economizer and thermal fluid heater service
- Various trim and material options available
- Repairable with replaceable nozzle and disc
- Certified on water for ASME B&PVC Section I

### **Electromatic™ 3500-5 Series Power-Actuated Relief Valve**

Max. Pressure: 4500 psig (310 barg)

Max. Temperature: 1150°F (620°C)

- Reduced maintenance with increased boiler efficiency
- Technologically advanced design offers operational excellence and improved cycle life
- Lower maintenance costs and extended life-cycle with technically advanced spray and fuse coating process for ball and seat assembly



1541 Series Safety Valve



2700 Series Safety Valve

# Consolidated Safety Relief Valve Applications

## Off-Boiler Safety Relief Valves – Unfired Pressure Vessel ASME B&PVC Section VIII

### Tube-side Feedwater Heater

#### Safety Relief Valves – Features

Trim selected for incompressible liquid service

Material selected to fight flashing water erosion

### Shell-side Feedwater Heater

#### Safety Relief Valves – Features

- Capacity requirement per ASME B&PVC Section VIII, the heater manufacturer and the application
- Discharge system and the back pressure requirements

### Deaerator Safety Relief Valves – Features

- Are well suited for high vibration environments
- Pilot operated safety relief valves excel in deaerator applications

### Sootblower, Reducing Station, and Extraction Steam Safety Relief Valves – Features

- Robust valves for demanding service
- Used where the control valve is not fast enough to regulate the system pressure

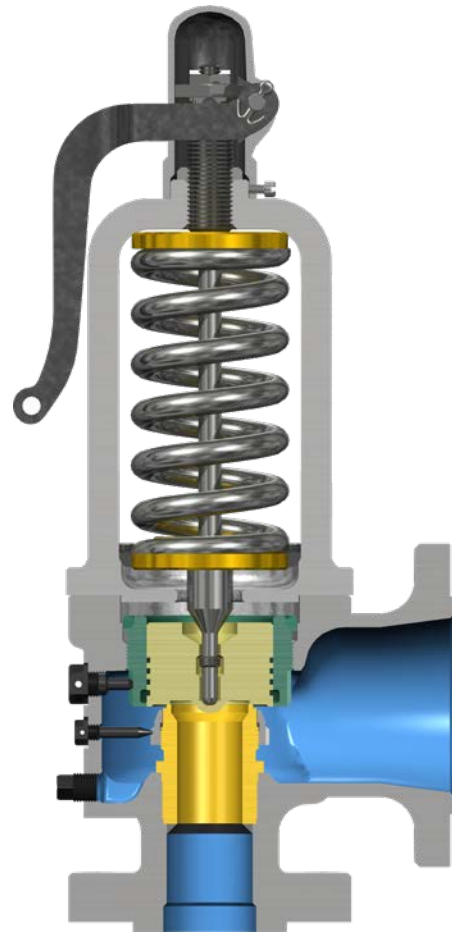

1811 Series Safety Valve





# Consolidated Safety Relief Valves

## The Right Safety Relief Valve Solutions for Your Applications

### 1900 Safety Relief Valve

Max. Pressure: 6250 psig (430 barg)

Max. Temperature: 1500°F (815°C)

- Suitable for the demanding requirements of off-boiler applications
- Trim and material options allow valves to be configured for specific applications and services
- Generous wall thickness for maximized set pressure, helps to lower costs and increases valve life
- Repairable with replaceable nozzle and disc

### 19000 Safety Relief Valve

Max. Pressure: 8000 psig (551 barg)

Max. Temperature: 1100°F (593°C)

- Cost-effective small size with threaded, welded or flanged connections
- Compact, light design lowers installation cost
- Trim and material options allow valves to be configured for specific applications and services

### 2900 and 3900 Pilot Operated Safety Relief Valve Types

Max. Pressure: 6250 psig (430 barg)

Max. Temperature: 1200°F (649°C)

- Innovative design for reliable performance
- Higher allowable operating pressures and temperatures increase plant profits
- Innovative modulating pilot valve with remote sensing tackles problems related to excessive inlet pressure drop, varying capacity loads and two-phase flow
- Expanded capabilities for high and low temperature applications

### 13900 Pilot Operated Safety Relief Valve

Max. Pressure: 300 psig (20 barg)

Max. Temperature: 550°F (288°C)

- Handles extra large capacity requirements up to 3,000,000 lbs. per hour
- Compact, light design lowers installation cost
- In-line disassembly and repair capability helps to lower repair cost



2900  
Pilot Operated  
Safety Relief Valve



1900  
Safety Relief Valve

# Power Applications

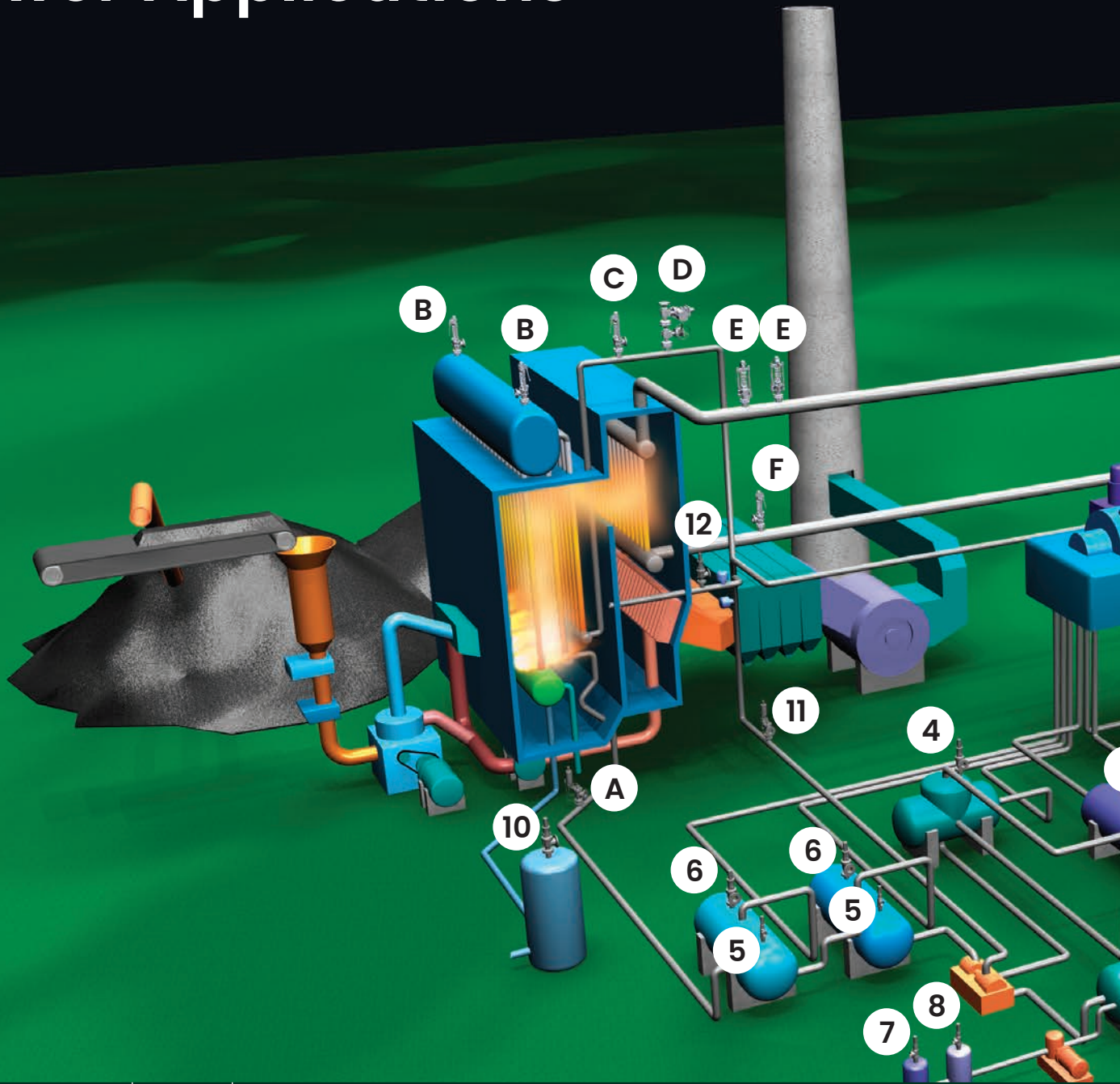

Applications	Legend	Safety Valves for Fired Boiler Applications									
		1700	2700	1811	1511	1541/ 1543	3500	1900P	1900 (Liquid Certified)	2900 (Liquid Certified)	2900-40
Economizer	<b>A</b>							<b>X</b>	<b>X</b>	<b>X</b>	<b>X</b>
Drum	<b>B</b>	<b>X</b>	<b>X</b>	<b>X</b>	<b>X</b>	<b>X</b>					<b>X</b>
Superheater Main Steam Line	<b>C</b>	<b>X</b>	<b>X</b>	<b>X</b>							
Power Actuated Relief Valve	<b>D</b>						<b>X</b>				
Cold Reheater Line	<b>E</b>	<b>X</b>	<b>X</b>	<b>X</b>							<b>X</b>
Hot Reheater Line	<b>F</b>	<b>X</b>	<b>X</b>	<b>X</b>							<b>X</b>

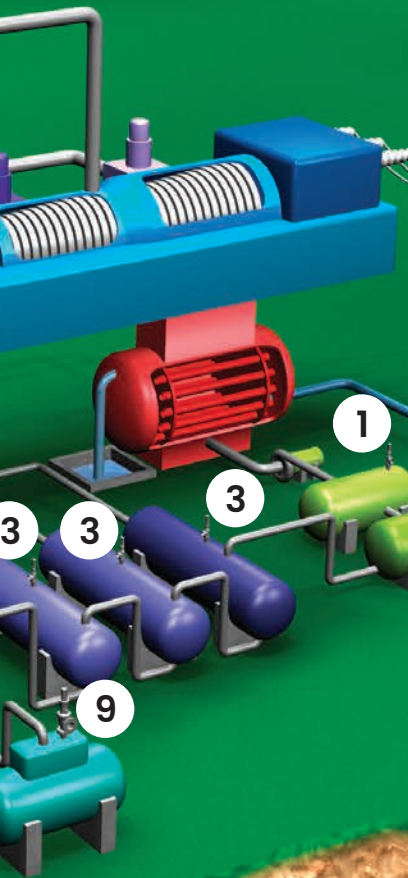

Applications	Legend	Safety Valves for Unfired Boiler Applications				
		1900	19000	2900-40	3900	13900
Hydrogen Cooler	<b>1</b>		X			
Oil Cooler	<b>2</b>		X			
L.P. Feedwater heaters	<b>3</b>	X	X			
Deaerators	<b>4</b>	X			X	
H.P. Feedwater heaters – Tube Side	<b>5</b>		X			
H.P. Feedwater heaters – Shell Side	<b>6</b>	X		X		
Economizer	<b>A</b>	X		X		
Make up Water Storage	<b>7</b>		X			
Chemical Feedwater Treatment	<b>8</b>		X			
Evaporator	<b>9</b>	X	X	X	X	
Flash Tank	<b>10</b>	X		X		
Reducing Valve	<b>11</b>	X		X		
Sootblower	<b>12</b>	X		X		
Applications not shown						
Turbine By Pass						X
Turbine Gland Seal		X		X	X	

# Consolidated

## Boiler Safety Valves



### 1700 Series Maxiflow Safety Valve

The Consolidated 1700 Series Maxiflow high pressure safety valve is a premium product that is installed on the majority of power generating stations worldwide to help protect boilers from overpressure conditions.

Inlet Sizes:	1.5" through 8"
Inlet Ratings:	ASME Class 600 through 4500 Flanged and BWE
Outlet Sizes:	3" through 10" flanged
Outlet Ratings:	ASME Class 150 and 300
Orifice Sizes:	11 sizes – 1 through T
Set Pressure Range:	100 to 5800 psig (6,90 to 400 barg)
Temperature Range:	Up to 1200°F (649°C)
Materials:	Alloy and carbon steel cast body with stainless steel trim
Certifications:	ASME B&PVC Section I and VIII, PED and SQL ISO 4126-1, 4126-3  IBR



### 2700 Series Safety Valve

The Consolidated 2700 Series safety valve can meet the specific requirements of the co-generation and waste-to-energy markets.

Inlet Sizes:	1.5" through 6"
Inlet Ratings:	ASME Class 600, 900 and 1500
Outlet Sizes:	3" through 8"
Outlet Ratings:	ASME Class 150 and 300
Orifice Sizes:	7 sizes – 1 through Q
Set Pressure Range:	100 to 1600 psig (6,90 to 110 barg)
Temperature Range:	Up to 1050°F (565°C)
Materials:	Alloy and carbon steel cast body with stainless steel trim
Certifications:	ASME B&PVC Section I and VIII, PED and SQL ISO 4126-1, 4126-3  IBR



## 1811 Series Safety Valve

The Consolidated 1811 Series safety valve is a cost-effective, high-capacity, flanged-steel safety valve for steam service.

Inlet Sizes: 1.25" through 6"

Inlet Ratings: ASME Class 300 and 600

Outlet Sizes: 1.5" through 8"

Outlet Ratings: ASME Class 150

Orifice Sizes: 10 sizes – F through Q

Set Pressure Range: 15 to 725 psig (1 to 50 barg)

Temperature Range: Up to 1000°F (538°C)

Materials: Alloy and carbon steel cast body with stainless steel trim

Certifications: ASME B&PVC Section I and VIII, PED and SQL ISO 4126-1, 4126-3



## 1511 Series Safety Valve

The Consolidated 1511 Series safety valve is configured for low pressure, steam-heating boilers and steam generators as well as air service applications.

Inlet Sizes: 1.5" through 6"

Inlet Ratings: ASME Class 250

Outlet Sizes: 2.5" through 4"

Outlet Ratings: ASME Class 125

Orifice Sizes: 8 sizes – H through Q

Set Pressure Range: 15 to 250 psig (1 to 17,24 barg)

Temperature Range: -20°F to 420°F (-29°C to 215°C)

Materials: Cast iron body with brass trim

Certifications: ASME B&PVC Section I and VIII, PED and SQL

# Consolidated

## Boiler Safety Valves



### 1541, 1543 Series Safety Valve

The Consolidated 1541 and 1543 Series safety valves are configured for steam and other compressible fluids. Compression media is limited to non-toxic, non-flammable, non-corrosive service. They are most commonly used in pharmaceutical and process plants.

Inlet Sizes:	.5" through 2.5"
Outlet Sizes:	.75" through 2.5"
Orifice Sizes:	D, E, F, G, H and J
Set Pressure Range:	15 to 350 psig (1 to 24,13 barg)
Temperature Range:	-20°F to 420°F (-29°C to 215°C)
Materials:	Cast iron bonnet with brass base and trim
Certifications:	ASME B&PVC Section I and VIII

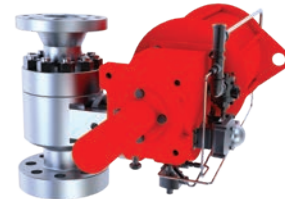

### 3500-5 Series Electromatic Ball Valve

The Consolidated 3500-5 Series Electromatic ball valve offers automatic or manual overpressure protection for steam boiler systems, and can also be used to assist start-up and shut-down venting.

Inlet Sizes:	1.5" / 2" / 2.5" / 3" / 4"
Inlet Ratings:	ASME Class 1500, 2500, 3100 and 4500
Outlet Sizes:	3" / 4" / 6"
Outlet Ratings:	ASME Class 300 and 900
Set Pressure Range:	50 to 6000 psig (3,45 to 414 barg )
Temperature Range:	Up to 1150°F (621°C)
Materials:	Alloy steel body with Colmonoy® coated inconel alloy seat and ball
Certifications:	ASME B&PVC Section I 'V' code stamp on once through boilers (full bore only) and non-code Section I



## 1900/P Series Safety Relief Valve

The Consolidated 1900/P Series steam internal series is configured for ASME B&PVC Section I non-power boiler and organic vapor service applications.

Inlet Sizes:	1" through 8"
Outlet Sizes:	2" through 10"
Outlet Ratings:	ASME Class 150 and 300
Orifice Sizes:	14 sizes – D through T
Set Pressure Range:	5 to 6000 psig (0,34 to 414 barg)
Temperature Range:	-20°F to 850°F (-29°C to 454°C)
Materials:	Carbon steel body with stainless steel trim
Certifications:	ASME B&PVC Section I and PED and SQL ISO 4126-1, 4126-3 IBR



## 2900-40 Series Pilot Operated Safety Valve

The Consolidated 2900-40 Series pilot operated safety valve offers superior performance while meeting the stringent requirements of boiler applications. This product is especially suited for economizer service and is certified to ASME B&PVC Code Case 2446. It offers maximum seat tightness and a shorter blowdown that can help to minimize steam loss. It also operates closer to set pressure.

Inlet Sizes:	1" to 12"
Outlet Sizes:	2" through 16"
Orifice Sizes:	12 sizes – D through Q
Outlet Ratings:	ASME Class 150 and 300
Set Pressure Range:	15 to 5800 psig (1 to 400 barg)
Temperature Range:	-40°F to 505°F (-40°C to 263°C) Above 505°F with heat exchanger
Materials:	Main Valve: Carbon steel base and 316 stainless steel internal components Pilot Valve: 316 stainless steel base and internal components
Certifications:	ASME B&PVC Section I ISO 4126-4

# Consolidated Off-Boiler Safety Relief Valves



## 2900 Series Pilot Operated Safety Relief Valve

The Consolidated 2900 Series pilot operated safety relief valve combines the strengths of two products into one—the 1900 safety relief valve and the 3900 POSRV. The 2900 Series POSRV can replace spring-loaded relief valves without requiring modified outlet piping.



## 3900 Series Pilot Operated Safety Relief Valve

The Consolidated 3900 Series pilot operated safety relief valve is a non-flowing design available in a modulating or pop action pilot. The 3900 POSRV is suitable for over pressure protection in many pressurized systems and vessels in the chemical, petrochemical, paper mill, oil and gas production and transmission industries.

Inlet Sizes: 1" through 12"

Outlet Sizes: 2" through 16"

Orifice Sizes: 17 sizes – D through W

Set Pressure Range: 15 to 6250 psig  
(1 to 431 barg)

Temperature Range: -40°F to 505°F (-40°C to 263°C)  
Above 505°F with heat exchanger

Materials: Stainless steel pilot with carbon steel  
main valve and stainless steel trim

Certifications: ASME B&PVC Section I (Liquid) and  
Section VIII  
PED and SQL  
ISO 4126-4

Inlet Sizes: 1" through 12"

Outlet Sizes: 2" through 16"

Orifice Sizes: 14 sizes – D through T (full bores)

Set Pressure Range: Full bores 15 to 6250 psig  
(1 to 431 barg)

Temperature Range: -40°F to 505°F (-40°C to 263°C)  
Above 505°F with heat exchanger

Materials: Stainless steel pilot with carbon steel  
main valve and stainless steel trim

Certifications: ASME B&PVC Section VIII  
PED and SQL  
ISO 4126-4





## 1900 Series (Liquid Certified) Safety Relief Valve

The highly adaptable Consolidated 1900 Series safety relief valve can meet numerous application requirements.

Inlet Sizes: 1" through 12"

Inlet Ratings: ASME Class 150 through 2500

Outlet Sizes: 2" through 16"

Outlet Ratings: ASME Class 150 and 300

Orifice Sizes: 17 sizes - D through W

Set Pressure Range: 4 to 6250 psig  
(0.27 to 431 barg)

Temperature Range: -450°F to 1500°F  
(-268°C to 815°C)

Materials: Cast carbon steel body  
with stainless steel trim

Certifications: ASME B&PVC Section I (Liquid),  
Section III & VIII  
PED and SQL  
ISO 4126-1, 4126-3



## 2900 Series (Liquid Certified) Pilot Operated Safety Relief Valve

The Consolidated 2900 Series (Liquid Certified) pilot operated safety relief valve offers superior performance while meeting the stringent requirements of boiler applications. This product is especially suited for liquid economizer and thermal heater fluid service service. It offers maximum seat tightness and a shorter blowdown that can help to minimize feed water loss. It also operates closer to set pressure.

Inlet Sizes: 1" to 12"

Outlet Sizes: 2" through 16"

Orifice Sizes: 17 sizes - D through W

Outlet Ratings: ASME Class 150 and 300

Set Pressure Range: 15 to 6250 psig  
(1 to 431 barg)

Temperature Range: -40°F to 505°F (-40°C to 263°C)  
Above 505°F with heat exchanger

Materials: Main Valve: Carbon steel base and  
316 stainless steel internal components  
Pilot Valve: 316 stainless steel base and  
internal components

Certifications: ASME B&PVC Section I (Liquid) &  
Section VIII  
ISO 4126-4

# Consolidated Off-Boiler Safety Relief Valves



## 4900 Series Pilot Operated Safety Relief Valve

The Consolidated 4900 Series pilot operated safety relief valve is a tubeless valve for oil and gas production and the offshore industry.

Inlet Sizes:	1" to 8"
Outlet Sizes:	2" through 10"
Orifice Sizes:	14 sizes – D through T
Set Pressure Range:	15 to 7200 psig (1 to 496 barg)
Temperature Range:	-40°F to 505°F (-40°C to 263°C)
Materials:	Stainless steel pilot with carbon steel main valve and stainless steel trim
Certifications:	ASME B&PVC Section VIII, PED and SQL ISO 4126-4



## 19000 Series Safety Relief Valve

The Consolidated 19000 Series valve is ASME B&PVC and PED certified. It meets and exceeds API seat tightness performance. The 19000 valve offers superior capacity and blowdown performance on many media types. In most cases, it does not require part changes to accommodate different media.

Inlet Sizes:	.5" to 2"
Outlet Sizes:	1" through 2.5"
Orifice Sizes:	0.096 sq. in. through 0.567 sq. in.
Set Pressure Range:	5 to 8000 psig (0,34 to 551 barg)
Temperature Range:	-425°F to 1100°F (-254°C to 593°C)
Certifications:	ASME B&PVC Section III and VIII, PED and SQL ISO 4126-1, 4126-3

### Options for 19000 Series

#### 19000-MS Standard Design

Metal-to-metal seat construction. Seat tightness-compliant with PI 527.

#### 19000-DA O-Ring Seat Design

Soft seat design offers bubble tight seats at up to 97 percent of valve set pressure for valves set at 101 psig (6.96 barg) and above. This option promotes higher, more efficient system operating pressures without seat leakage concerns.



## 1900 Series Safety Relief Valve

The highly adaptable Consolidated 1900 Series safety relief valve can meet numerous application requirements.

Inlet Sizes: 1" through 12"

Inlet Ratings: ASME Class 150 through 2500

Outlet Sizes: 2" through 16"

Outlet Ratings: ASME Class 150 and 300

Orifice Sizes: 17 sizes - D through W

Set Pressure Range: 4 to 6250 psig  
(0.27 to 431 barg)

Temperature Range: -450°F to 1500°F  
(-268°C to 815°C)

Materials: Cast carbon steel body  
with stainless steel trim

Certifications: ASME B&PVC Section III and VIII,  
PED and SQL  
ISO 4126-1, 4126-3

### Options for 1900 Series

#### 1900-30

The Consolidated 1900-30 Series valve includes the addition of a balanced bellows to compensate for the effects of variable back pressure. By isolating the upper structure and allowing the use of less expensive materials, the bellows is also a cost-effective solution in applications where the valve is exposed to highly viscous or corrosive fluids.

#### 1900-DA Series

The Consolidated 1900-DA Series valve contains an additional O-ring seat seal. This soft seat is the primary seal and allows the valve to remain leak free at 95 percent of set pressure over 100 psig (6.89 barg). A backup metal seat provides additional safety for critical fire-relief applications when O-rings can be destroyed by high-temperature exposure. The 1900-DA Series O-ring seat is available for set pressures up to 6250 psig (430.92 barg). Some soft seats offered by other manufacturers are limited to 1500 psig (103,42 barg).

## Direct Sales Office Locations

### Australia

Brisbane  
Phone: +61-7-3001-4319

Perth  
Phone: +61-8-6595-7018

Melbourne  
Phone: +61-3-8807-6002

### Brazil

Phone: +55-19-2104-6900

### China

Phone: +86-10-5738-8888

### France

Courbevoie  
Phone: +33-1-4904-9000

### India

Mumbai  
Phone: +91-22-8354790

New Delhi

Phone: +91-11-2-6164175

### Italy

Phone: +39-081-7892-111

### Japan

Tokyo  
Phone: +81-03-6871-9008

### Korea

Phone: +82-2-2274-0748

### Malaysia

Phone: +60-3-2161-03228

### Mexico

Phone: +52-55-3640-5060

### Russia

Veliky Novgorod  
Phone: +7-8162-55-7898

Moscow

Phone: +7-495-585-1276

### Saudi Arabia

Phone: +966-3-341-0278

### Singapore

Phone: +65-6861-6100

### South Africa

Phone: +27-11-452-1550

### South & Central America and the Caribbean

Phone: +55-12-2134-1201

### Spain

Phone: +34-935-877-605

### United Arab Emirates

Phone: +971-4-8991-777

### United Kingdom

Phone: +44-7919-382-156

### United States

Houston, Texas

Phone: +1-713-966-3600

Find the nearest local Channel Partner in your area:  
[valves.bakerhughes.com/contact-us](http://valves.bakerhughes.com/contact-us)

## Tech Field Support & Warranty:

Phone: +1-866-827-5378  
[valvesupport@bakerhughes.com](mailto:valvesupport@bakerhughes.com)

[valves.bakerhughes.com](http://valves.bakerhughes.com)

**Baker Hughes** 